



Violet Township Fire Department

Chief Michael J. Little
8700 Refugee Road NW • Pickerington, OH 43147-9572

Phone: 614.837.4123
Fax: 614.837.1975

Your Friends For Life

January 22, 2019

To: All Local Building & Zoning Officials

From: Violet Township Fire Department (VTFD), Fire Prevention Office (FPO)

RE: 2019 New Construction Requirements Documents

Please find attached, our updated *2019 New Construction Requirements* documents, which are directly related to the 2017 Ohio Fire Code.

Annually, we provide these documents to all local area building inspectors, chief building officials, plans examiners, zoning officials, contractors, and design professionals doing construction in our district.

Our office is now requiring all site plans submitted shall contain a submittal sheet which ONLY shows the following:

1. Access widths for any roadways, streets, any parking area lanes of travel and/or fire lanes
2. "Auto-turn" renderings to illustrate emergency apparatus access
3. All assigned street names and addresses
4. Water supplies detailing water main size(s), location(s) and fire hydrant locations

We request ***NO OTHER SITE PLAN DETAILS SHALL BE INCLUDED on the plans. The items listed SHALL BE EXCLUSIVE to the VTFD – FPO submittal(s) for review:***

We highly encourage all design professionals / contractors / vendors to connect and schedule a preconstruction meeting with our FPO Inspectors to review all submittals. Please contact the FPO office @ 614-837-4123 to schedule a consultation or answer questions regarding these requirements.

Thank you in advance for your assistance in complying with our new request.

VIOLET TOWNSHIP FIRE DEPARTMENT
8700 REFUGEE RD
PICKERINGTON, OHIO 43147
614-837-4123

FIRE PROTECTION REQUIREMENTS FOR NEW CONSTRUCTION

The Violet Township Fire Department (VTFD) being the Fire Authority Having Jurisdiction (AHJ) has established the following Fire Protection requirements to aid developers and architects in planning new construction within our jurisdictional boundaries. VTFD will require electronically submitted plans with the following specific items detailed on an *individual drawing / overlay with NO OTHER Utilities etc.*

1. *Access showing street and parking isle widths*
2. *Turning radius, as per these listed guidelines*
3. *Water supplies, i.e. fire hydrants and any fire suppression connections (“FDC”) locations*

All prospective developers and contractors shall setup a pre-design meeting to review these VTFD requirements during their project planning process. Any and all building owner(s) / occupant(s) contractors, vendors, tenant landlords, etc. shall become familiar with these requirements.

FIRE DEPARTMENT ACCESS:

1. Public road /street widths shall be a minimum of 30 feet in width for Commercial/Industrial Development, and a minimum of 26 feet in width for Planned Subdivision Development (Unobstructed, Islands in entrances, Cul-de-Sacs, etc., shall not be included in the calculation for street widths.)
******Access for All Emergency Apparatus SHALL be maintained during the entire construction phase.***
2. Fire Lane locations shall be determined by the Fire AHJ; shall be a minimum of 25 feet wide; and shall be properly signed and striped. *Alternative fire lane construction methods shall meet accessibility requirements in all environmental conditions, 24 / 7 / 365 days a year.*
3. Fire Lanes shall be lawfully denoted by signage and all applicable pavement markings.
4. Outside turning radius shall be a minimum of 51 feet. (See attached diagram)
5. Overhead clearance shall be a minimum of 13 feet 6 inches.
6. **Key Boxes:** As per Rule 5, Section 506 of the 2017 Ohio Fire Code: At least one approved (TBD by AHJ) **Knox Rapid Entry System key box** (or boxes) shall be installed in a location determined by the Fire AHJ, approximately 5 feet above finished grade. Not limited to only secure key boxes, AHJ will determine if additional secure boxes are needed for large buildings or complexes, and /or any other “control” switches, such as gate access & electrical shut-offs / elevator controls, or hazardous materials documents.
7. Street names and addresses shall be submitted for review by the Fire AHJ prior to final approval. All street address numbers shall be visible from the public street at night and affixed on both front and rear of the buildings.
8. Signage as required by the AHJ for First Responder for both interior and exterior of complex, building, business, and /or tenant space(s) showing access to, but NOT Limited to:
Mechanical Areas / Fire Suppression Control Room(s) / Fire Alarm Control Panel(s) / Roof Access etc.

FIRE HYDRANTS:

1. Public and private fire service mains and appurtenances shall be a minimum of an 8-inch line.
2. Spacing between fire hydrants along public or private streets shall not exceed 350 feet. The minimum distance to the building that a fire hydrant can be located is 50 feet.
3. Commercial buildings shall have a hydrant located within 200' of the location the first due fire apparatus is most likely to arrive. The location shall not cross or interfere with an artery of traffic flow.
4. Fire hydrants shall have a 5-inch "Storz" fitting attached to the steamer port, plus two additional 2-1/2 inch side discharge ports equipped with National Standard Hose Thread. (All Threads provided for fire department connections to sprinkler systems, standpipe systems, yard hydrants or any other fire hose connection shall be compatible with the connections utilized by the local fire department.)
4. All hydrants shall be installed, inspected, tested, and approved in accordance with all applicable NFPA Standard and shall meet the local water purveyor's fire hydrant specifications.

SPRINKLER SYSTEM:

1. Provide a 5-inch "Storz" fitting with a cap that's capable of being secure by use of the "Knox Key" and a 30 degree turn-down, for ALL Fire Department Connections (FDCs).
2. The Fire Department Connection shall be located within **75'-100' (feet) (TBD by AHJ)** of a fire hydrant. Remote connections shall have approval of Fire Department AHJ provided access and protection from vehicle traffic, in the same manner as a fire hydrant. Fire Department AHJ shall approve all FDC locations. The location shall not cross or interfere with an artery of traffic flow.
3. FDC testing: All fire department connections shall be required to pass a hydrostatic test (200# per 2 hours) as required for the building fire suppression system. All FDC lines shall be flushed prior to final approval and witnessed by the fire AHJ.
4. FDC shall be labeled per AHJ- "VTFD", and shall be permanently mounted on all fire department connections serving fire sprinklers, standpipes, or fire pump connections. **Horn / Strobe light located outside in place of water gong / bell.**
5. Fire hydrant and FDC located on the same side of the street.
6. Provide an audible and visual alarm on the outside wall above the Fire Department Connection. Subject to approval by AHJ.
7. All sprinkler control valves must be supervised with tamper devices connected to the fire protection supervisory system and to a central station alarm service.
8. The sprinkler system shall be installed in accordance with all applicable NFPA Standards.

STANDPIPE SYSTEMS:

1. Standpipe systems shall comply with all the requirements of all applicable NFPA standards for a Class III Standpipe System (2 ½ inch hose connections) including minimum flow rates and residual pressure requirements. **All fittings capped and capable of being secure by use of the “Knox Key.”**
2. An adequate number of class II standpipes shall be installed to allow any point in the building to be reached by a 100-foot length of hose and a 25-foot water stream. Standpipe connections shall be required at all designated Exit Locations.
3. Fire Hose/Fire Hose Racking installations **SHALL NOT** be installed for use by building occupants without prior approval from the Fire AHJ. Where the building is protected throughout by an approved automatic sprinkler system, hose stations for use by the building occupants shall not be required, subject to the approval of the AHJ.
4. A shut-off valve shall be provided at each hose connection location.

FIRE ALARM SYSTEMS:

1. Fire Alarm Systems shall require prior review with the Fire AHJ
(Systems shall be addressable; which indicates on the panel readout exactly what device is in alarm or trouble) ***VTFD Strongly Encourages the Use of Cellular Communications Systems***
2. Fire Alarm System installations and testing shall comply with all the requirements in accordance of all applicable NFPA standards
3. A remote fire alarm enunciator panel located near a front (and/or rear) entry point, by the Knox box and operable by any first responder
4. There will be posted at all fire alarm control panel(s) (FACP) (and a copy given to Fire AHJ) a diagram of the facility floor plan(s) with the specific location of all devices as shown on the FACP
5. The following information shall be posted on FACP & available for FD:
 - a. **central station monitoring company name**
 - b. **central station monitoring contact number**
 - c. **any & all necessary account passwords / pass codes related to the occupancy**
 - d. **any & all necessary passwords related to the fire alarm systems**
 - e. **any & all necessary Fire Alarm Control Panel (FACP) Passwords / Pass Codes**

EMERGENCY RESPONDER COMMUNICATIONS:

All buildings shall have approved radio coverage for emergency responders to meet Rule 5, Section 510 of the 2017 Ohio Fire Code.

VEHICLE IMPACT PROTECTION:

As per Rule 3, Section 312 of the 2017 Ohio Fire Code

CYLINDER / TANK STORAGE of Compressed Gases (Including Propane, Carbon Dioxide etc.)

As per Rule 53, and 61 of the 2017 Ohio Fire Code

References: 2017 Ohio Fire Code, Applicable NFPA Standards, 2017 Ohio Building Code

VIOLET TOWNSHIP FIRE DEPARTMENT
FIRE APPARATUS TURNING RADIUS REQUIREMENTS

Maximum Turning Radius	(A) - 50' 9"
Minimum Turning Radius	(B) - 47' 9"
Minimum Inside Radius	(C) - 35' 1"
Vehicle Width	(D) - 8' 5"
Wheel Base	(E) - 23' 8"
Vehicle Height	12' 0"
Vehicle Length	42' 0"

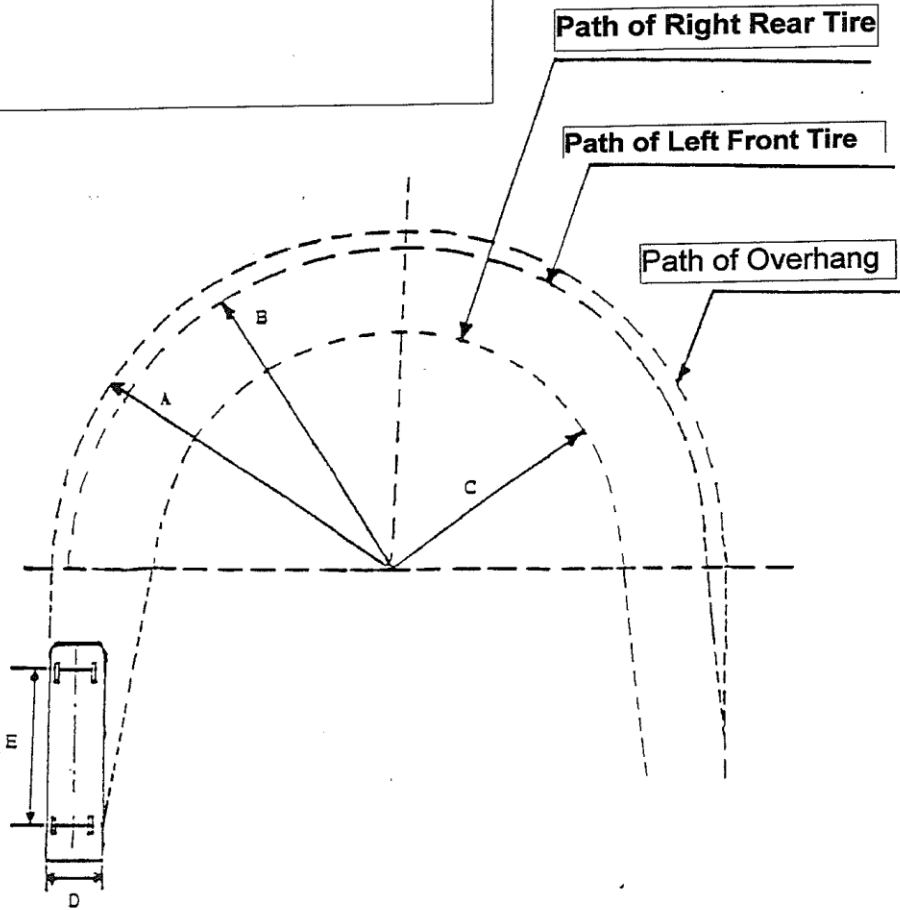

Fire Apparatus Turning Requirements

Preconstruction Document Packet:

- Fire Department New Construction Requirements
- Knox Box Order Form & Key Registration On line Access
Required Number and Locations of Knox Boxes:

1. _____ 2. _____ 3. _____ 4. _____

- Final Inspection Form
- Violet Township Fire Department Contact Information
Fire Prevention Office 614-837-4123

- Building Contact Information:
******All Inspection Requests MUST be phoned into the appropriate Building Dept.***
Pickerington = 614-833-2221
Violet Township = 614-575-5559
Canal Winchester = 614-837-7501
Reynoldsburg = 614-322-6820

- Project Information:

Name: _____

Assigned Address: _____

Site Contact: Name - _____ # = _____

Projected Life Safety & Final Inspection Dates: _____

This document shall remain on site at all times with the building card for review by Fire Safety Inspectors.